

DH152/DR152

General Features

The model DH152 or DR152 grinder pump station is a complete unit that includes: two grinder pumps, check valve, polyethylene tank, controls, and alarm panel. A single DH152 or DR152 is ideal for up to four, average single-family homes and can also be used for up to 12 average single-family homes where codes allow and with consent of the factory.

- Rated for flows of 3000 gpd (11,356 lpd)
- 150 gallons (568 liters) of capacity
- Indoor or outdoor installation
- Standard outdoor heights range from 93 inches to 160 inches

The DH152 is the “hardwired,” or “wired,” model where a cable connects the motor controls to the level controls through watertight penetrations.

The DR152 is the “radio frequency identification” (RFID), or “wireless,” model that uses wireless technology to communicate between the level controls and the motor controls.

Operational Information

Motor

1 hp, 1,725 rpm, high torque, capacitor start, thermally protected, 120/240V, 60 Hz, 1 phase

Inlet Connections

4-inch inlet grommet standard for DWV pipe. Other inlet configurations available from the factory.

Discharge Connections

Pump discharge terminates in 1.25-inch NPT female thread. Can easily be adapted to 1.25-inch PVC pipe or any other material required by local codes.

Discharge

15 gpm at 0 psig (0.95 lps at 0 m)
11 gpm at 40 psig (0.69 lps at 28 m)
7.8 gpm at 80 psig (0.49 lps at 56 m)

Accessories

E/One requires that the Uni-Lateral, E/One’s own stainless steel check valve, be installed between the grinder pump station and the street main for added protection against backflow.

Alarm panels are available with a variety of options, from basic monitoring to advanced notice of service requirements.

The Remote Sentry is ideal for installations where the alarm panel may be hidden from view.

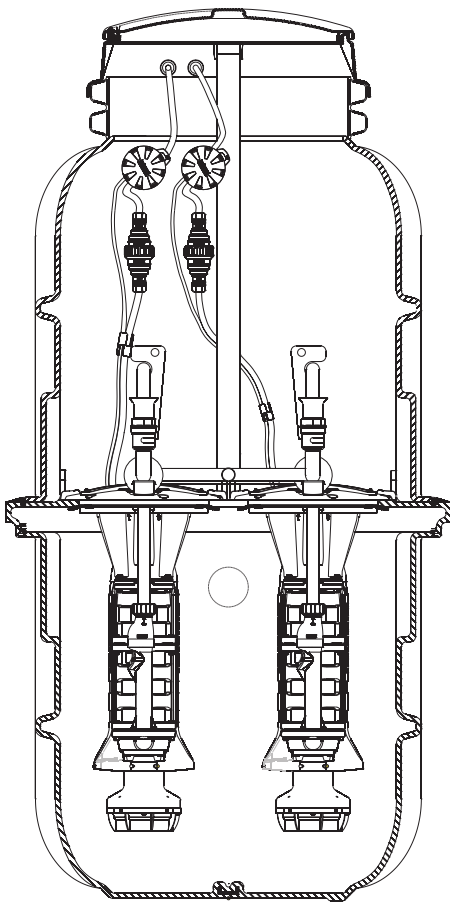

OPTIONS: DH152 (HARD WIRED LEVEL CONTROLS)
 DR152 (WIRELESS LEVEL CONTROLS)

FIELD JOINT REQUIRED FOR MODELS
 DH152-129 / DR152-129
 &
 DH152-160 / DR152-160

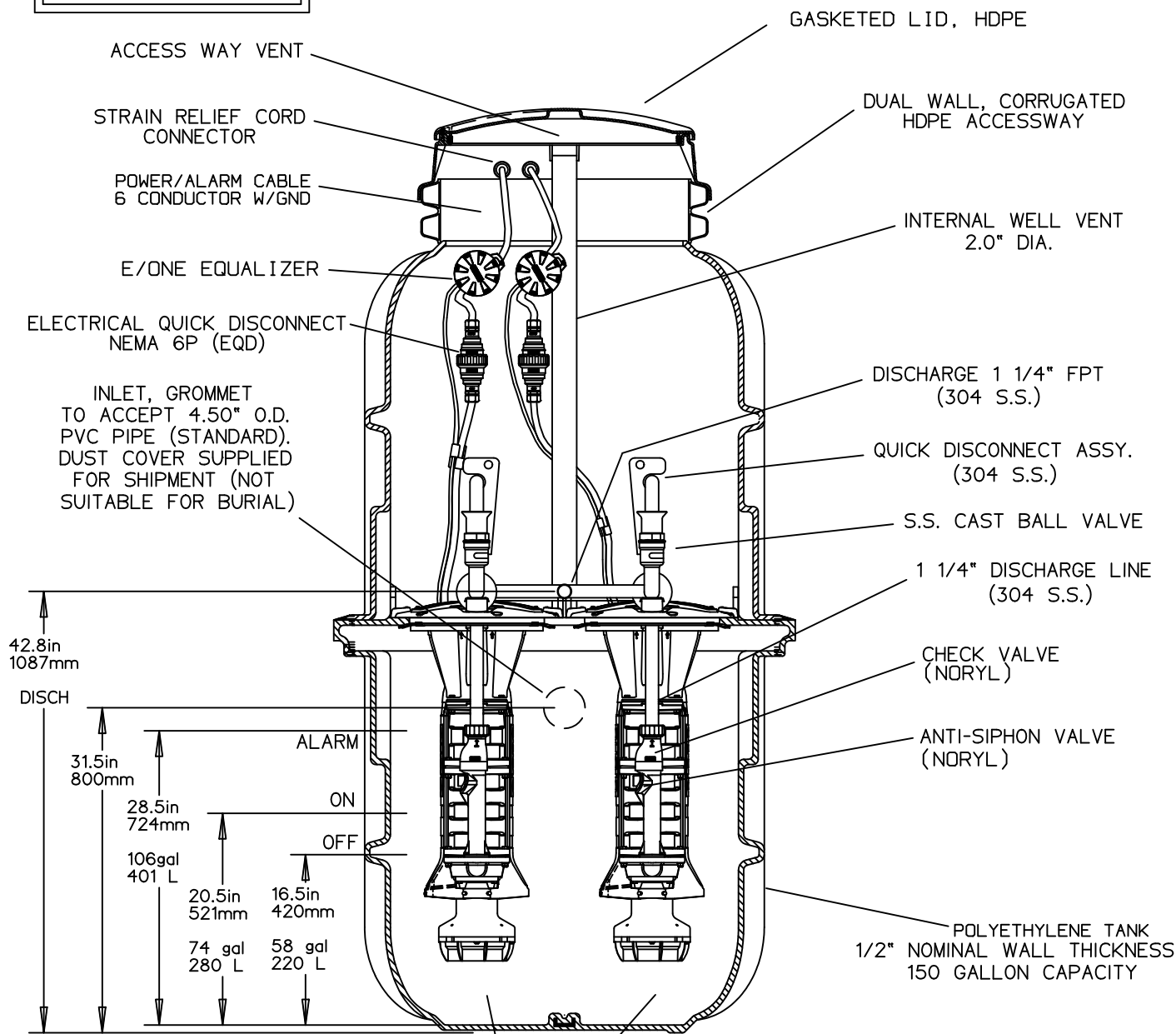

42.8in
1087mm

DISCH

31.5in
800mm

28.5in
724mm

106gal
401 L

20.5in
521mm

16.5in
420mm

74 gal
280 L

58 gal
220 L

ALARM ON OFF

SEMI-POSITIVE DISPLACEMENT TYPE PUMP EACH DIRECTLY DRIVEN BY A 1 HP MOTOR

CONCRETE BALLAST MAY BE REQUIRED SEE INSTALLATION INSTRUCTIONS FOR DETAILS

NOTE: DIMENSIONS ARE FOR REF ONLY

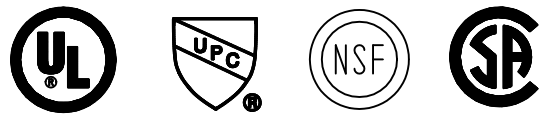

KC	PD	09/30/19	F	
DR BY	CHK'D	DATE	ISSUE	SCALE



MODEL DH152 / DR152
 DETAIL SHEET

NA0052P02

DH152-38

NO BAFFLE

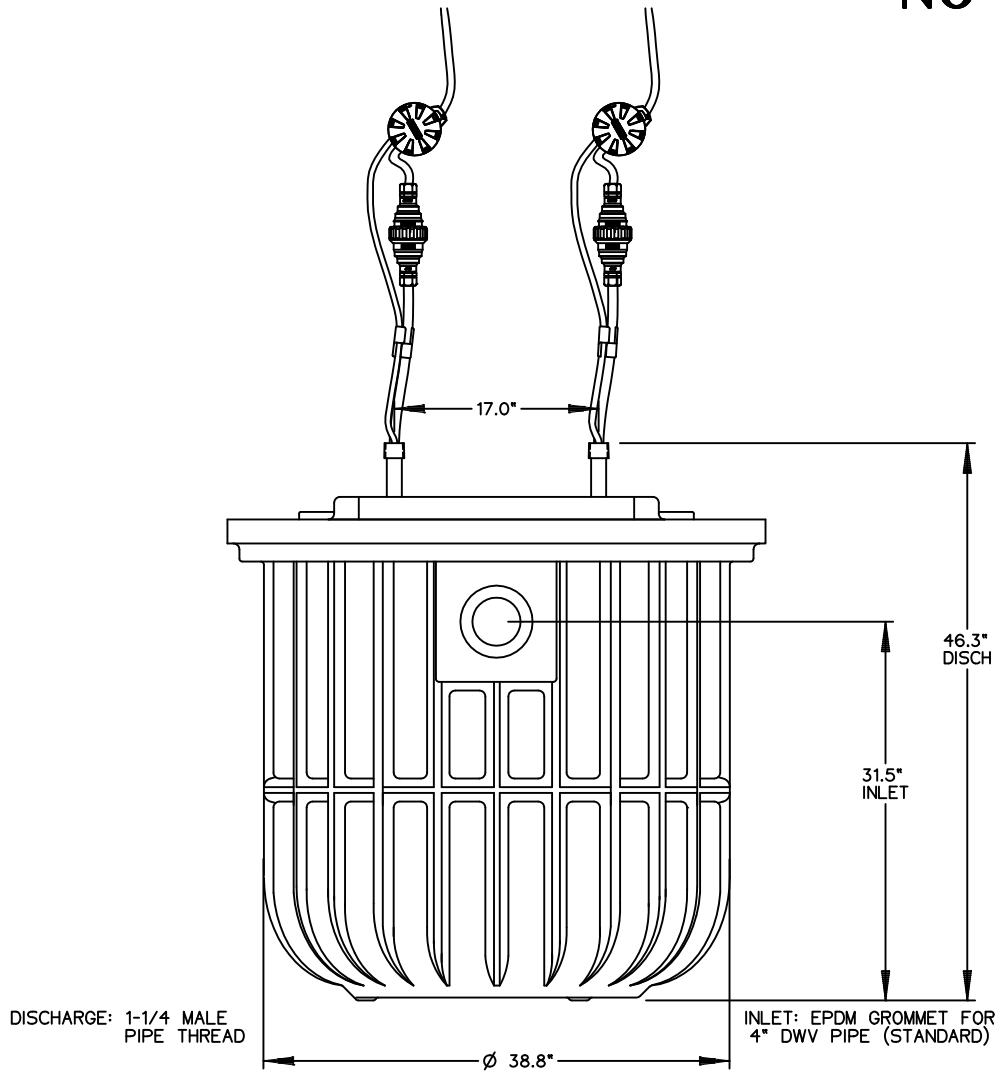

NOTE: DIMENSIONS ARE FOR REF ONLY



CTT	CH	10/19/12	D	
DR BY	CHK'D	DATE	ISSUE	SCALE



MODEL DH152-38, NO BAFFLE

NA0052P03

OPTIONS : **DH152 -93**

(HARD WIRED
LEVEL CONTROLS)

DR152 -93

(WIRELESS
LEVEL CONTROLS)

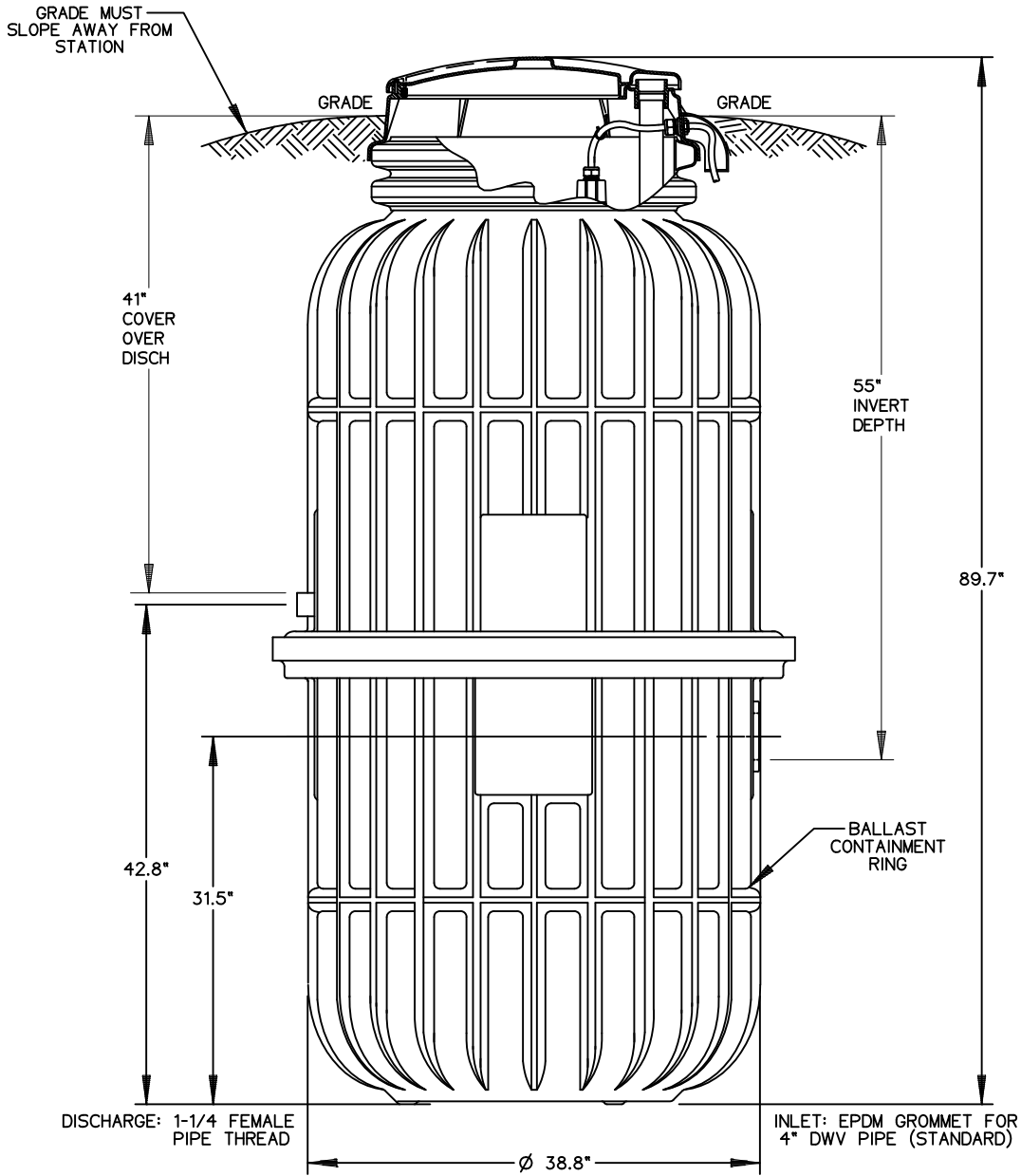

CONCRETE BALLAST MAY BE REQUIRED
SEE INSTALLATION INSTRUCTIONS
FOR DETAILS

NOTE: DIMENSIONS ARE FOR REF ONLY



AD	CAH	7/13/07	C	1/16
DR BY	CHK'D	DATE	ISSUE	SCALE



MODEL DH152-93 / DR152-93

NA0052P04

OPTIONS : **DH152 -129** (HARD WIRED LEVEL CONTROLS)
 DR152 -129 (WIRELESS LEVEL CONTROLS)

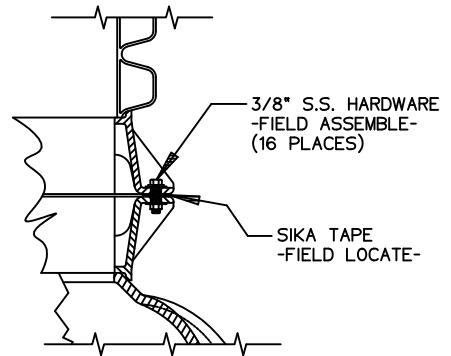
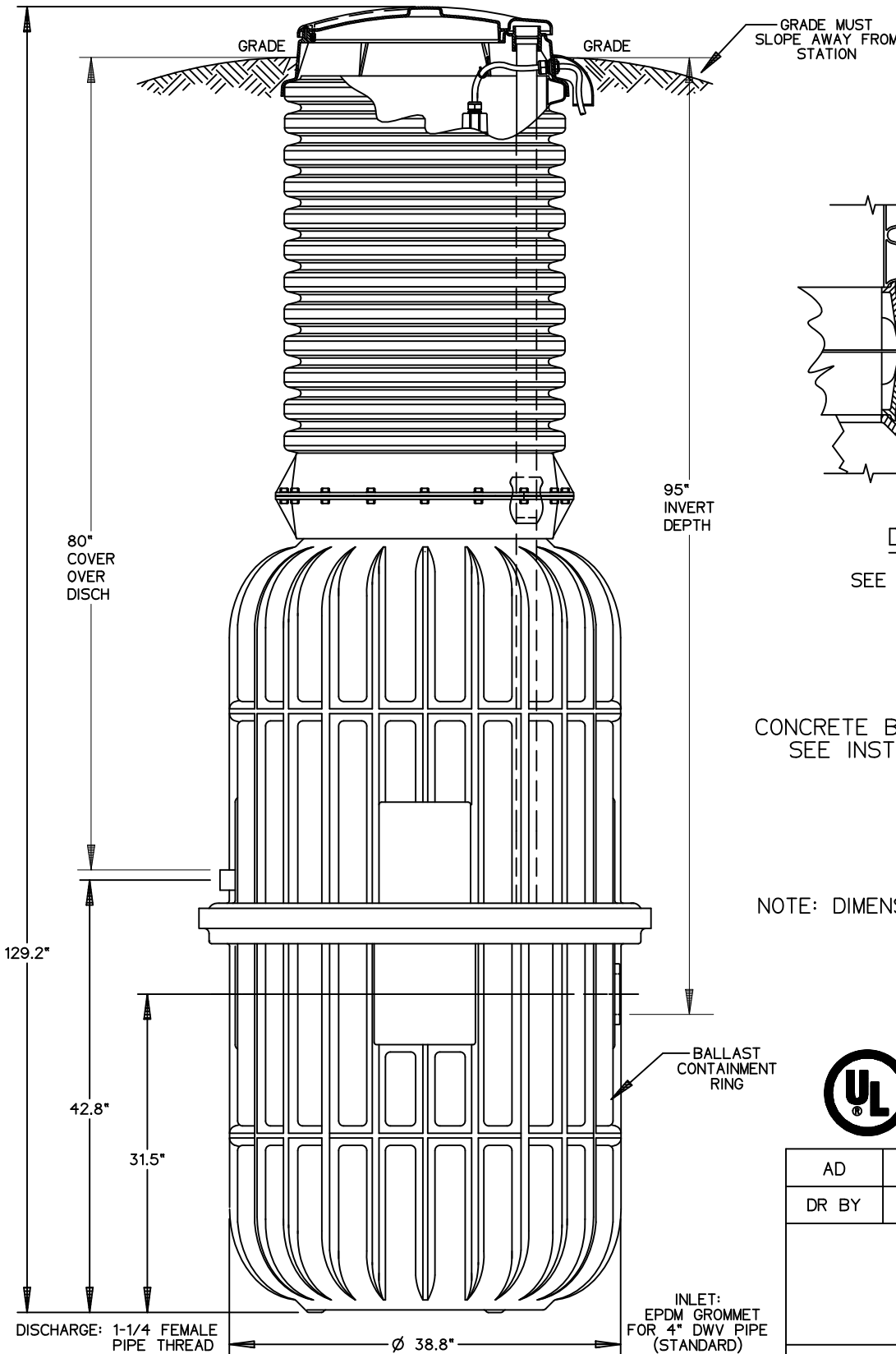

DETAIL, FIELD JOINT

SEE INSTALLATION INSTRUCTIONS FOR FURTHER DETAILS

CONCRETE BALLAST MAY BE REQUIRED
SEE INSTALLATION INSTRUCTIONS FOR DETAILS

NOTE: DIMENSIONS ARE FOR REF ONLY



AD	CAH	7/13/07	C	1/16
DR BY	CHK'D	DATE	ISSUE	SCALE



MODEL DH152-129 / DR152-129

NA0052P05

OPTIONS : **DH152-160** (HARD WIRED LEVEL CONTROLS)

DR152-160 (WIRELESS LEVEL CONTROLS)

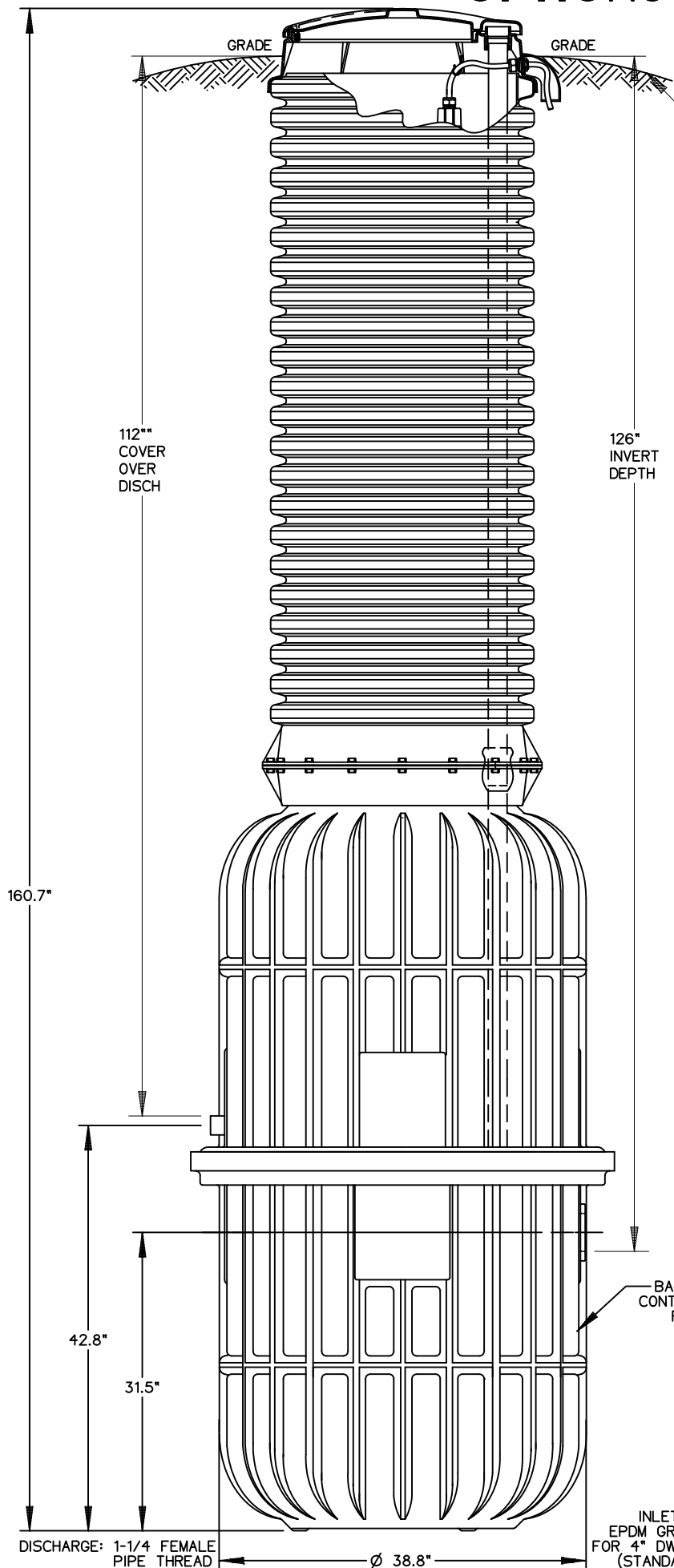

GRADE MUST SLOPE AWAY FROM STATION

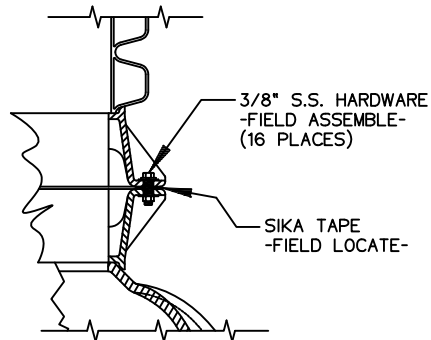

DETAIL, FIELD JOINT
SEE INSTALLATION INSTRUCTIONS
FOR FURTHER DETAILS

CONCRETE BALLAST MAY BE REQUIRED
SEE INSTALLATION INSTRUCTIONS
FOR DETAILS

NOTE: DIMENSIONS ARE FOR REF ONLY



AD	CAH	7/13/07	C	1/16
DR BY	CHK'D	DATE	ISSUE	SCALE



MODEL DH152-160 / DR152-160

NA0052P06

DH152-57

BUILDERS MODEL

STRAIGHT DISCHARGE

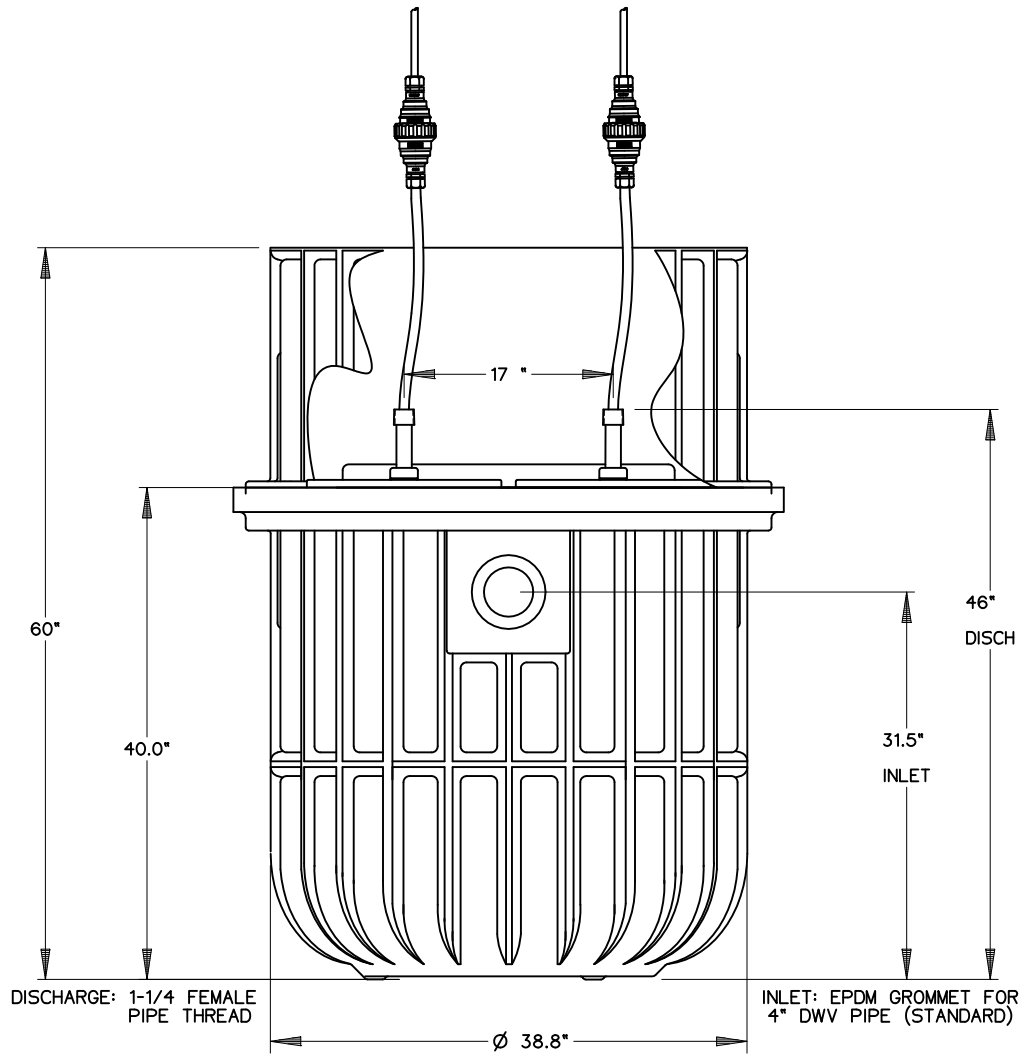

NOTE: DIMENSIONS ARE FOR REF ONLY

AD	CAH	06-27-07	C	1/16
DR BY	CHK'D	DATE	ISSUE	SCALE



MODEL DH152-57
BUILDERS

NA0052P07

DH152-57

BUILDERS MODEL

DISCHARGE VALVE

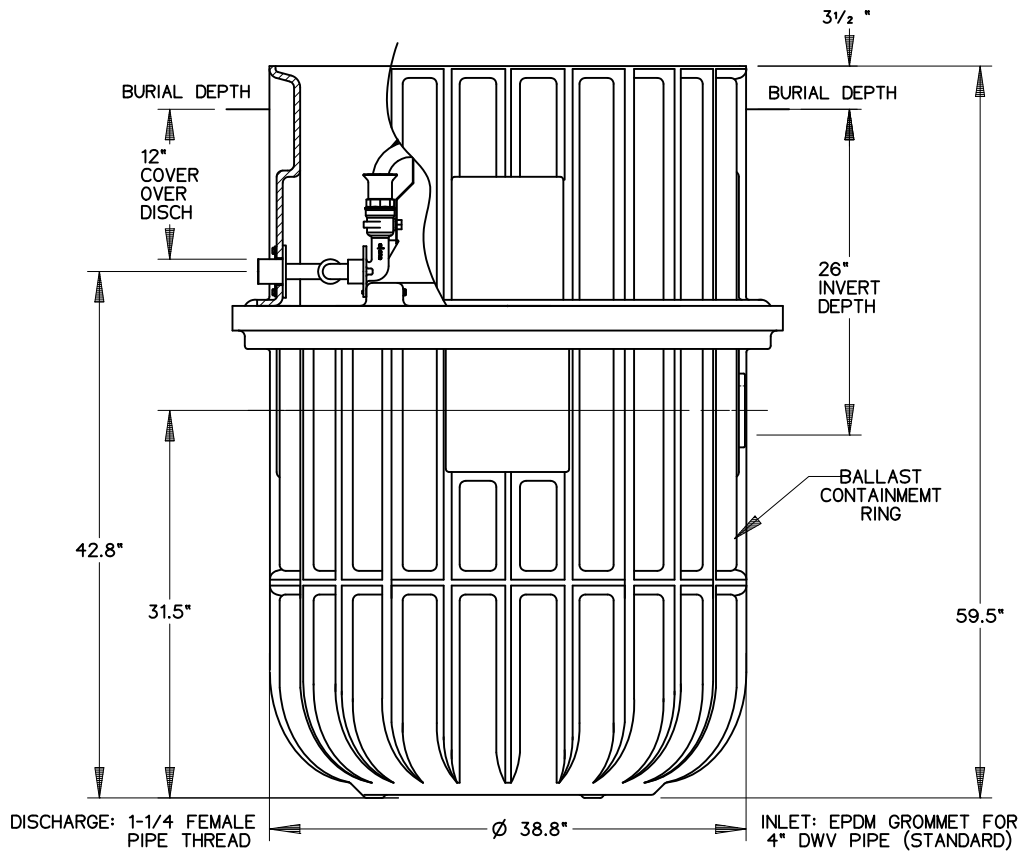

NOTE: DIMENSIONS ARE FOR REF ONLY

AD	CAH	06/27/07	C	1/16
DR BY	CHK'D	DATE	ISSUE	SCALE



MODEL DH152-57
BUILDERS

NA0052P08