



TO:	Walpole Conservation Commission	DATE:	1-21-21
FROM:	Katie Enright, PE	HSH PROJECT NO.:	19097
SUBJECT:	55 Summer Street, Proposed chain link fence		

Proposed Fence Extension

The Walpole Zoning Board of Appeals has requested that the Design Team for Cedar Crossing request a continuous fence along the railroad tracks long the eastern project boundary. Previously the design plan called for a continuous fence except where the fence would be located within a 50 ft buffer of an isolated or bordering vegetated wetland. A continuous fence along the tracks would provide 123 feet of chain link fence construction within the isolated vegetated wetland and 14 feet of chain link fence construction within the bordering vegetated wetland with a total fence length of 2,675 linear feet.

The fence, at a 10 ft post separation would account for approximately 14 posts. The fence is proposed to be constructed with a minimum gap of 6" at the bottom of the fence to allow for transmission of small and medium sized animals (raccoon, coyote, skunk, possum, snapping turtle, etc.)

The work to construct this fence would be completed between July and November and it is our opinion that this could be accomplished with de minimus disturbance.

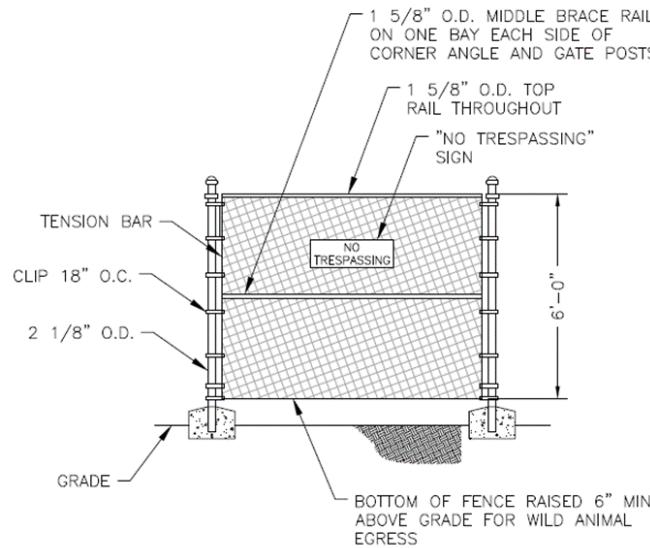

PERIMETER FENCE DETAIL
NOT TO SCALE

- NOTES:
 1. SIGN MUST BE LOCATED AT EYE LEVEL AND LOCATED ON ALL GATES. DISTANCE BETWEEN SIGNS MUST NOT EXCEED 50'.